

CLEONI

LIGHTING

P O R T F O L I O

© Copyright 2021

P O R T F O L I O C L E O N I
2 0 2 1

“RECOGNIZING THE NEED IS THE
PRIMARY CONDITION FOR DESIGN.” CHARLES EAMES

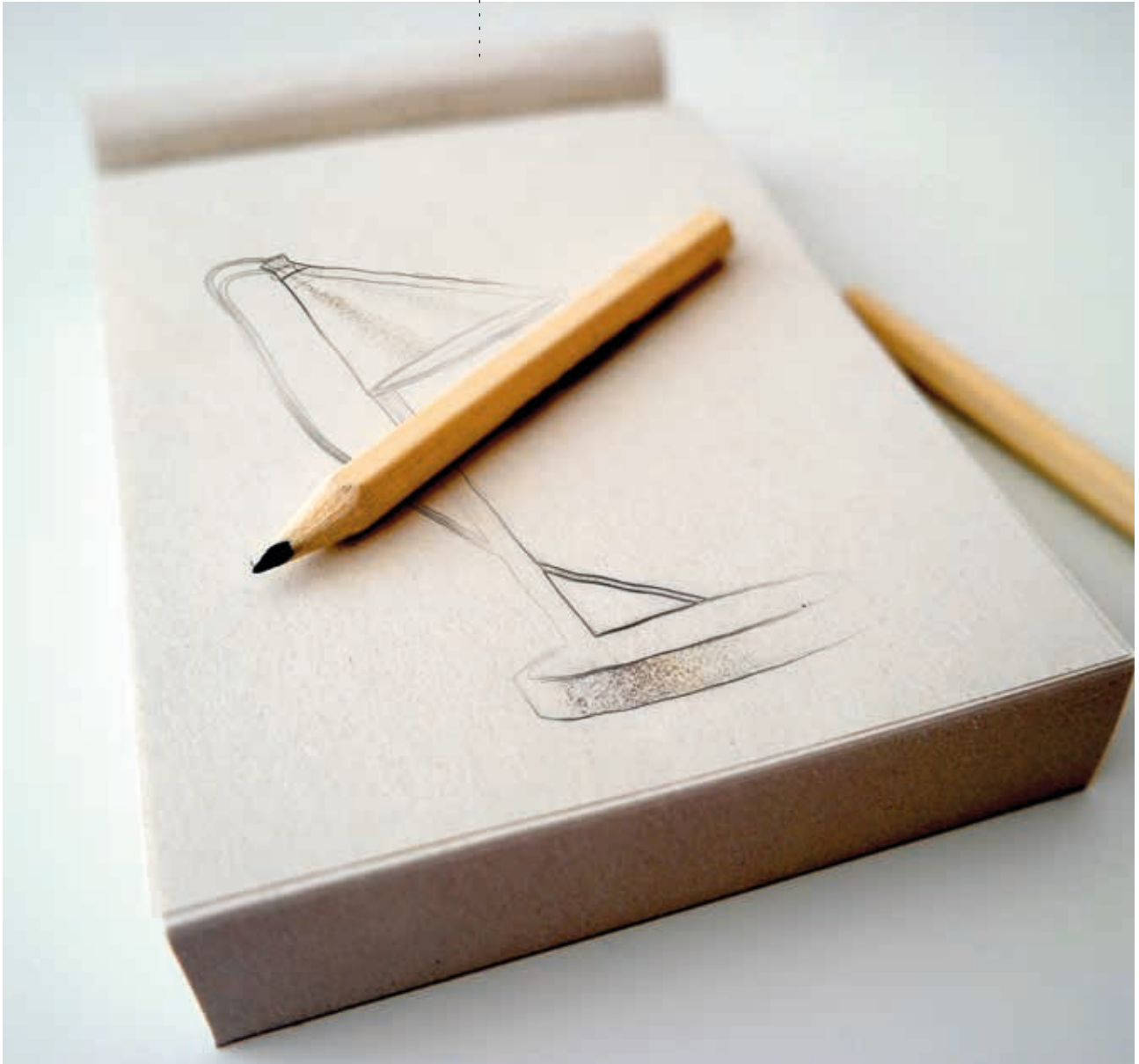

S Ł O W O W S T Ę P N E

Drogi Czytelniku,

Witamy w świecie opraw Cleoni - w którym nowoczesność i minimalizm idzie w parze z dekoracyjnością, którą można znaleźć w każdej naszej oprawie.

W tym świecie każdy element jest wynikiem starannego i przemyślanego rozważania.

Właśnie dlatego oprawy nie tylko spełniają praktyczną rolę, ale również potrafią podkreślić styl wnętrza, w którym się znajdują.

Te artystycznie zaprojektowane oprawy łączą w sobie nowoczesną technologię z wyrafinowanym designem w doskonałej harmonii. Przyjemne dla oka, tworzą fantastyczną atmosferę w każdym pomieszczeniu.

Przyjemnej lektury.

C L E O N I

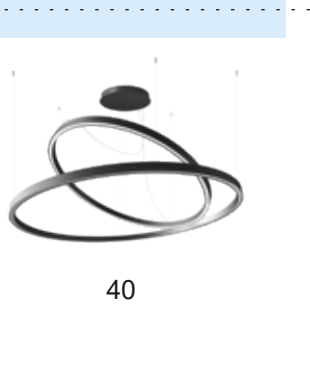
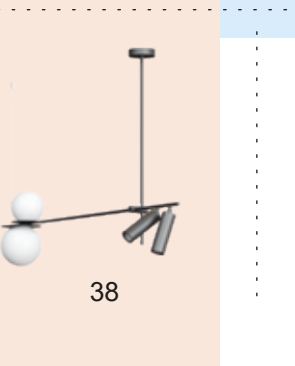
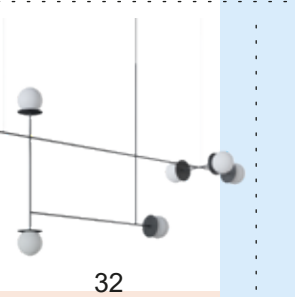
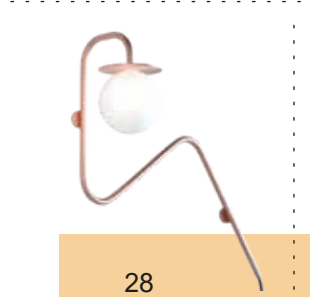
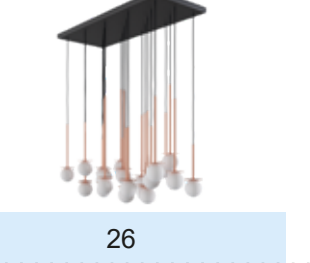
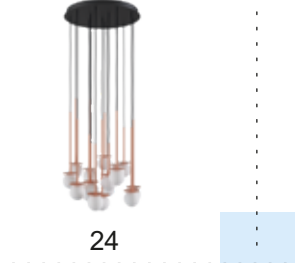
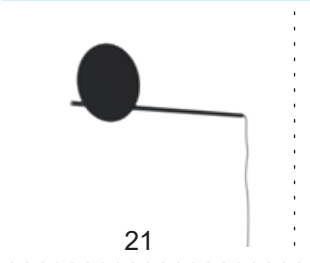
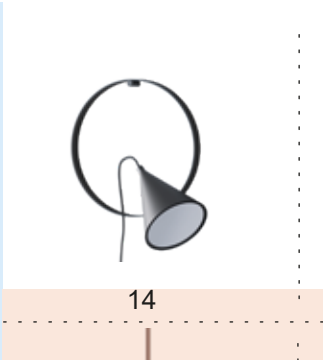
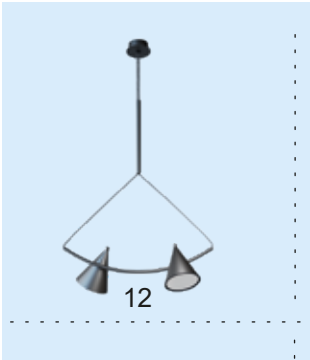



42



44



46



48



52



54



56



58



60



62



64



66



68



70



72



74



76



78



80



82



84



86



88



KOLEKCJA RIM

“Kolekcja Rim to lampy o prostym, graficznym kształcie. Obręcz, czyli “rim”, jest istotnym elementem budującym tę kolekcję. Projektując oprawy, starałam się stworzyć produkty, których funkcja wynikałaby z formy, przy minimalnym jej skomplikowaniu.

W ramach rodziny jest lampa ścienna, której montaż nie wymaga specjalnego przygotowania instalacji elektrycznej - jest po prostu wieszana na ścianie i zasilana z gniazda.

Lampa wisząca, dzięki użyciu metalowej rurki, pozwala na szybką i łatwą regulację wysokości. Dopełnienie kolekcji stanowi lampka biurkowa, w której kabel, jeśli jest za długi, można owinąć wokół pionowego ramienia.”

*Katalia
Wieteske*

BACK

RIM WISZĄCA / LA39C1

OPRAWA WISZĄCA: RIM

ŹRÓDŁO ŚWIATŁA: 2XLED

MATERIAŁ: STAL

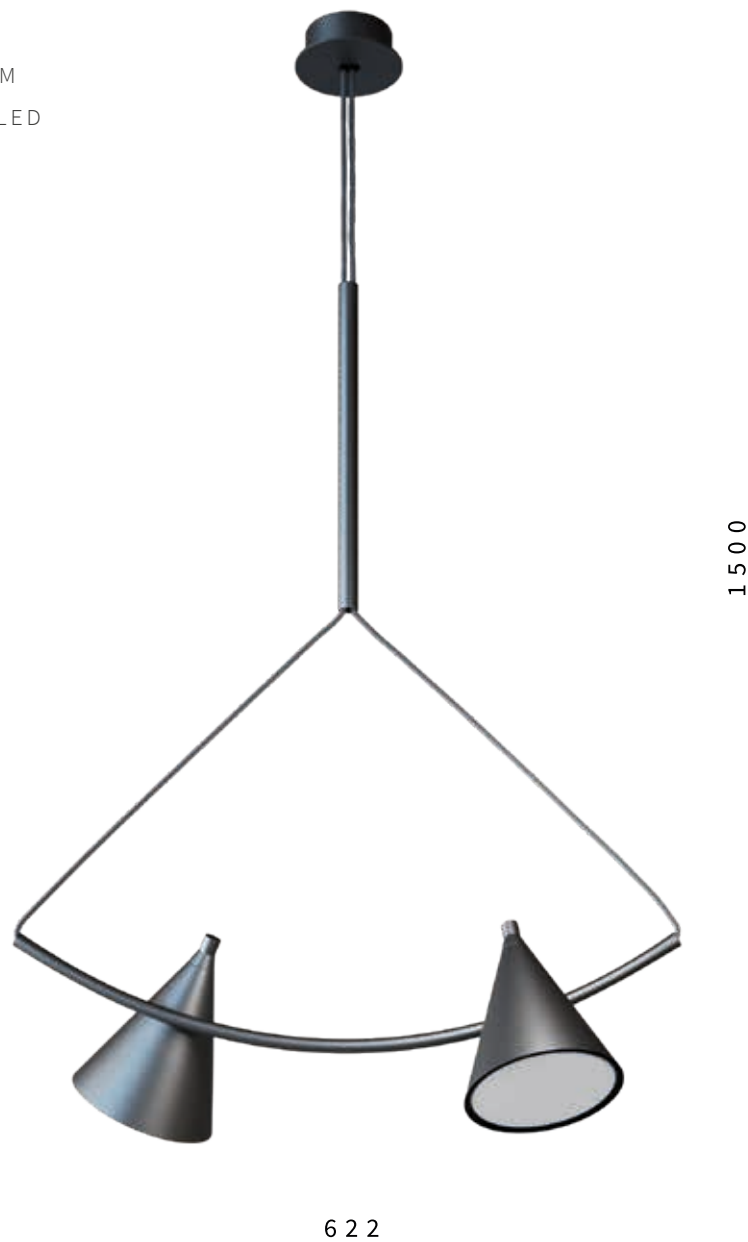



“RIM” DESIGN BY
NATALIA WIETESKA



RIM KINKIET/ LA39A

OPRAWA - KINKIET: RIM

ŹRÓDŁO ŚWIATŁA: LED

MATERIAŁ: STAL

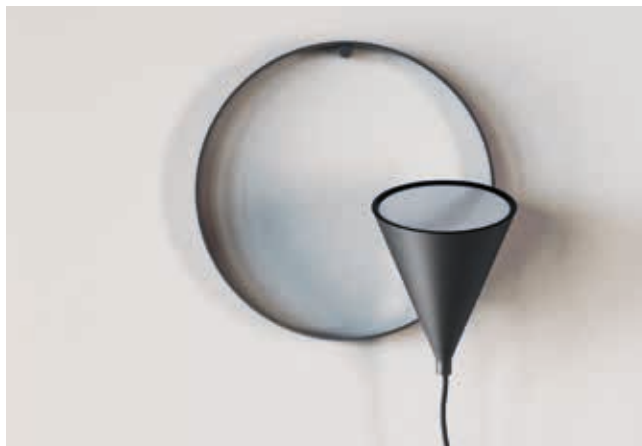
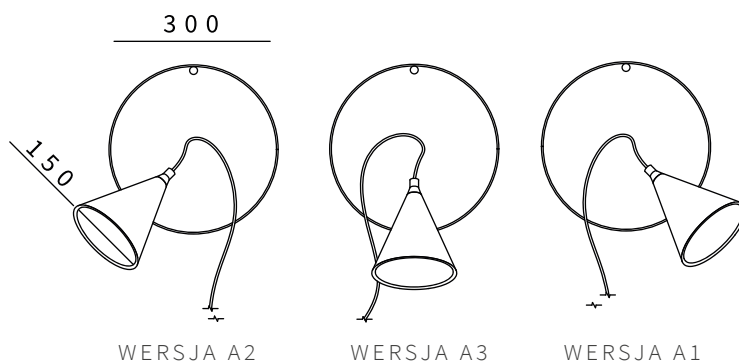

BACK

RIM BIURKOWA / LA39B1

OPRAWA BIURKOWA: RIM

ŹRÓDŁO ŚWIATŁA: LED

MATERIAŁ: STAL

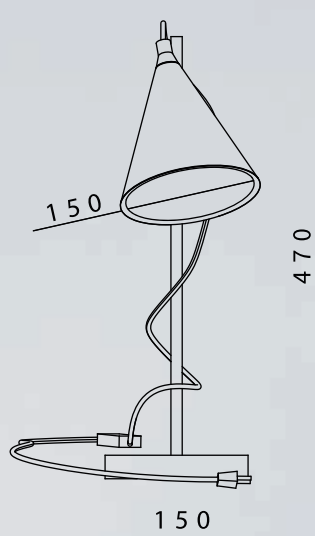



“RIM” DESIGN BY
NATALIA WIETESKA

KOLEKCJA PILL

“Lampy z kolekcji Pill mają harmonijny kształt i zgrabne proporcje. Dzięki temu odnajdą się w bardzo różnych wnętrzach, niezależnie od tego, czy będzie to jedna lampa, czy grupa kilku opraw Pill.

Lampa ścienna ma typowo graficzny charakter - przy użyciu kilku sztuk, można komponować z niej ciekawe kompozycje, jednocześnie dodając do wnętrza subtelne, nastrojowe światło. Kabel, biegnący przez metalową rurkę, jest ciekawym estetycznie i celowo wyeksponowanym elementem projektu. Wisząca oprawa Pill to symetryczne połączenie dwóch “tabletek” - jedna z nich to podświetlony, szklany klosz druga to kontrastujący metal. Lampa ma ponadczasowy wygląd, daje też dużo światła, przez co może być użyta zarówno nad stołem, wyspą kuchenną czy barem.”

*Natalia
Wieteske*



“PILL” DESIGN BY
NATALIA WIETESKA

BACK

PILL WISZĄCA / LA19A1

OPRAWA WISZĄCA: PILL

ŹRÓDŁO ŚWIATŁA: LED

MATERIAŁ: SZKŁO „HANDMADE”, STAL



BACK

PILL KINKIET/ LA19

OPRAWA - KINKIET: PILL

ŹRÓDŁO ŚWIATŁA: LED

MATERIAŁ: STAL

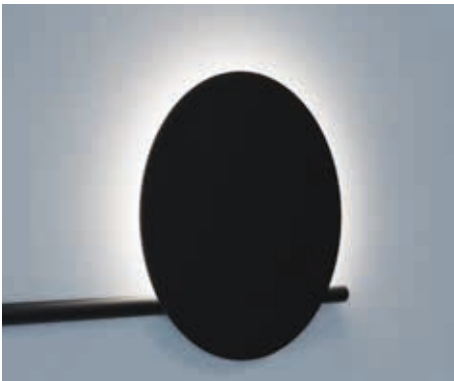
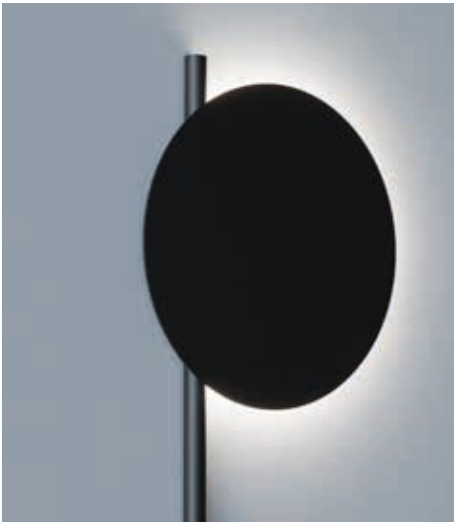
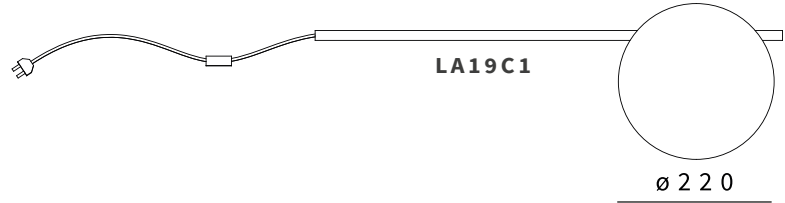
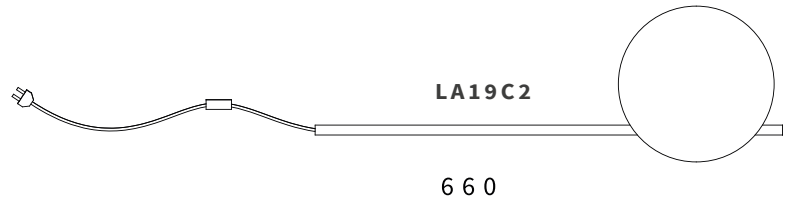



COTTON PANEL-CLEONI

STOISKO TARGOWE WARSAW HOME

COTTON WISZĄCA/ WPUST STROPOWY

OPRAWA WISZĄCA/ WPUST STROPOWY: COTTON

ŹRÓDŁO ŚWIATŁA: G9

MATERIAŁ: SZKŁO „HANDMADE”, STAL

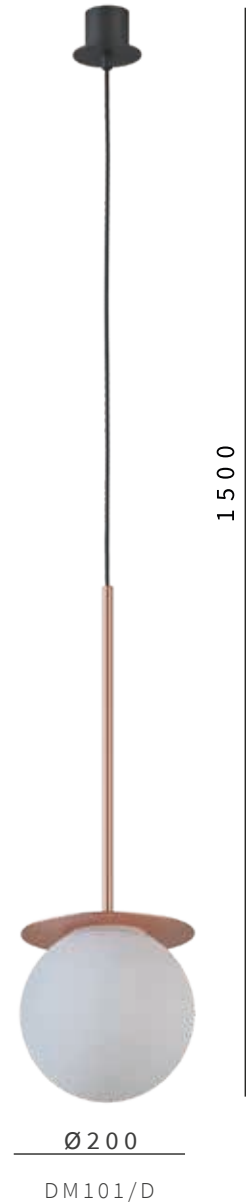

COTTON PANEL WISZĄCA / DM101



OPRAWA WISZĄCA: COTTON PANEL

ŹRÓDŁO ŚWIATŁA: G9

MATERIAŁ: SZKŁO-Ø100 „HANDMADE”, STAL



"GOOD DESIGN IS OBVIOUS
GREAT DESIGN IS TRANSPARENT." JOE SPARANO



COTTON PANEL
HF2 LUB ET

QBACK



COTTON PANEL
HF3

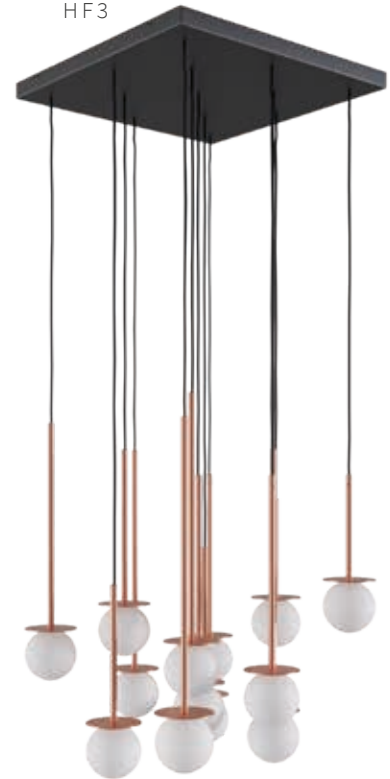

COTTON PANEL WISZĄCA / DM101

OPRAWA WISZĄCA: COTTON PANEL

ŹRÓDŁO ŚWIATŁA: G9

MATERIAŁ: SZKŁO-Ø100 „HANDMADE”, STAL

BACK

COTTON KINKIET/ DM101

OPRAWA KINKIET: COTTON KINKIET

ŹRÓDŁO ŚWIATŁA: G9

MATERIAŁ: SZKŁO-Ø100 „HANDMADE”, STAL



WERSJA LEWA-
DM101/LA42/A1/L

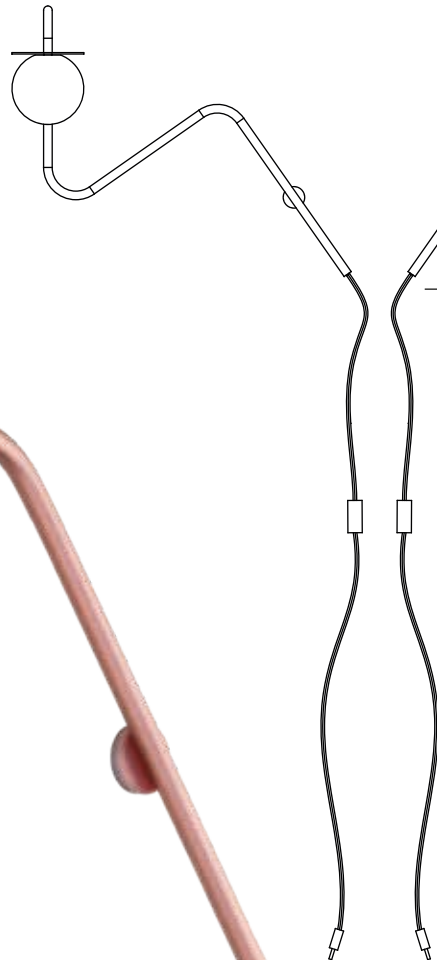

WERSJA PRAWA-
DM101/LA42/A1/P

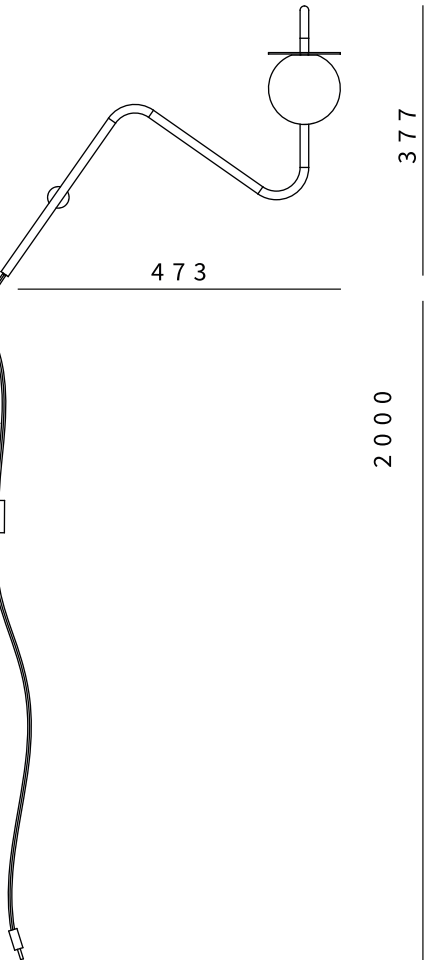

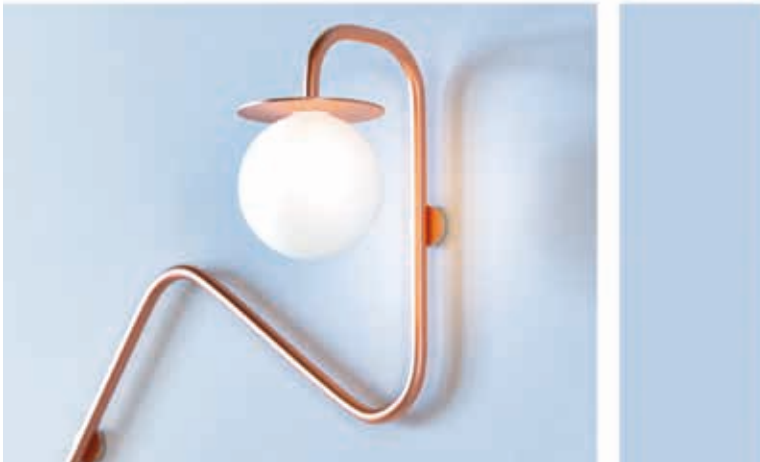
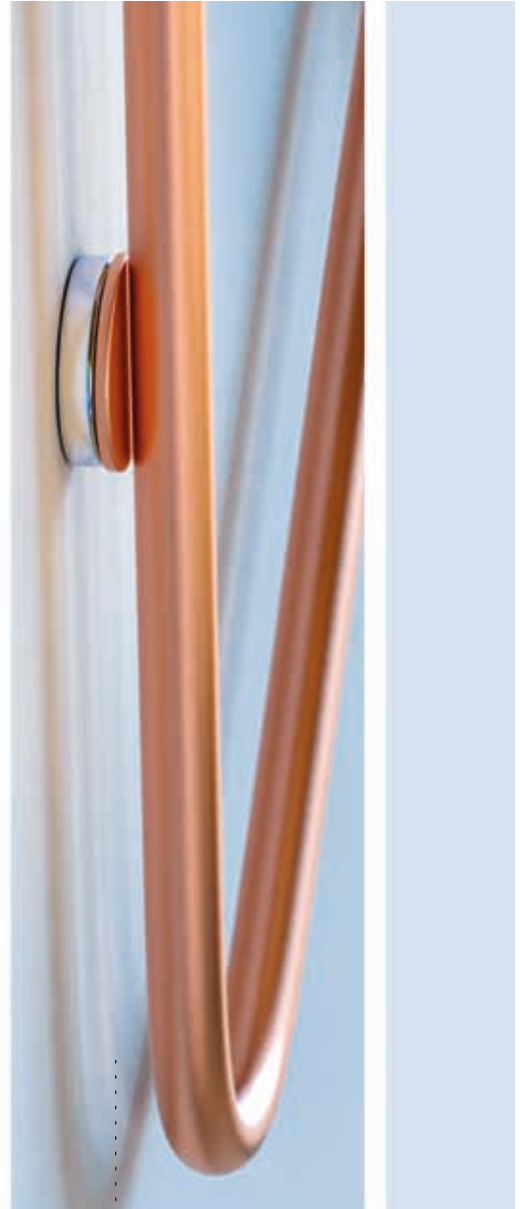

“DESIGN IS A PLAN FOR ARRANGING ELEMENTS IN SUCH A WAY AS BEST TO ACCOMPLISH A PARTICULAR PURPOSE.” CHARLES EAMES

TC1

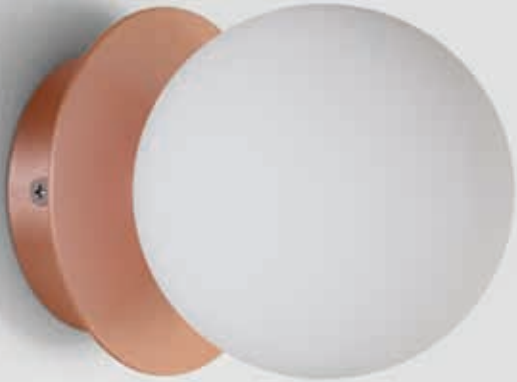

TR1



COTTON KINKIET

RS2



TR1



BACK

COTTON KINKIET/ DM101

OPRAWA-KINKIET: COTTON KINKIET

ŹRÓDŁO ŚWIATŁA: G9

MATERIAŁ: SZKŁO-Ø100 „HANDMADE”, STAL



BACK

VARIANT WISZĄCA/ LA123A1

OPRAWA WISZĄCA: VARIANT

ŹRÓDŁO ŚWIATŁA: 7XE27

MATERIAŁ: STAL,
SZKŁO-Ø200 „HANDMADE”

2783

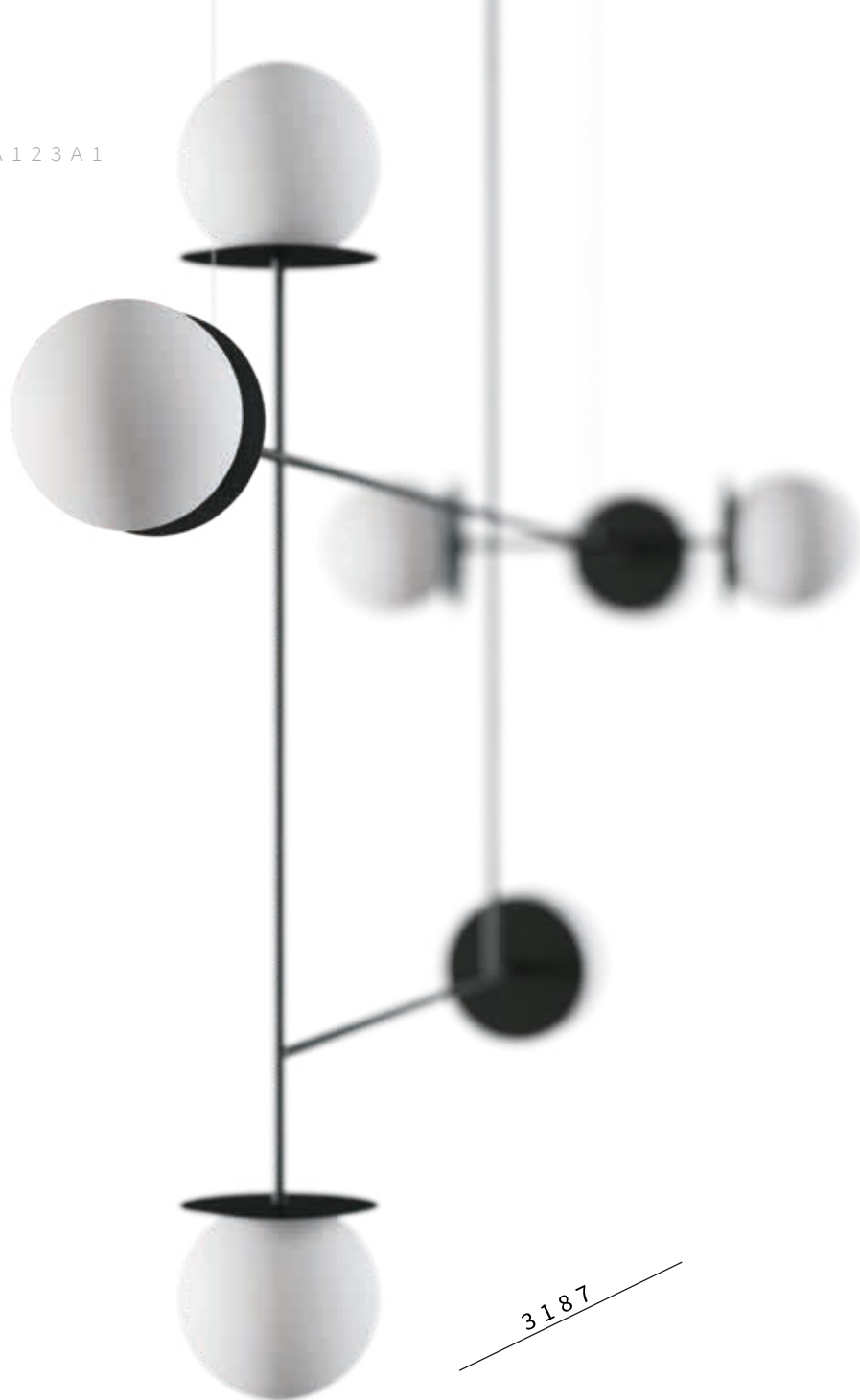

3187

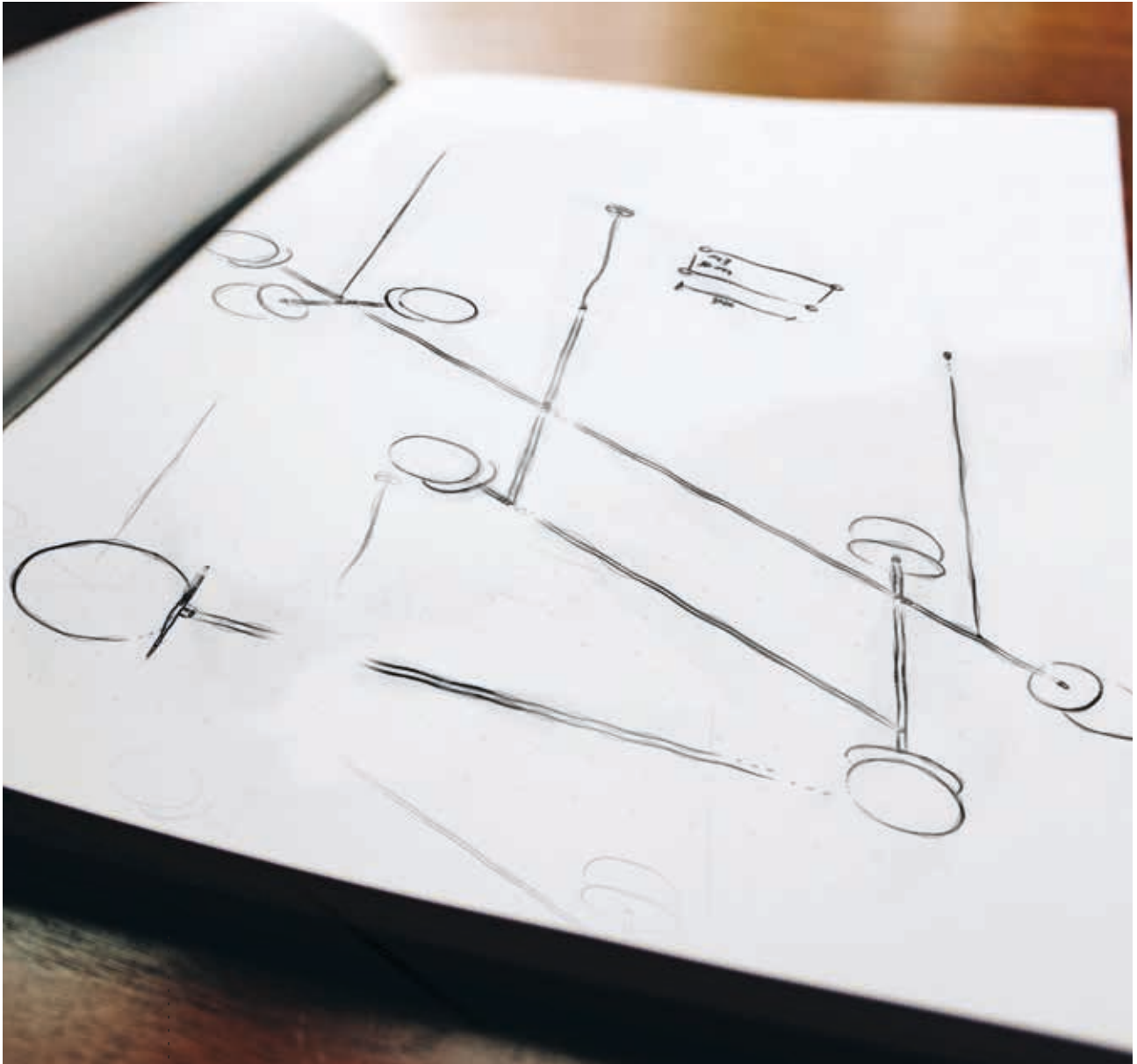

OVO WISZĄCA / DM145

OPRAWA WISZĄCA: OVO

ŹRÓDŁO ŚWIATŁA: E27

MATERIAŁ: SZKŁO „HANDMADE”

STAL

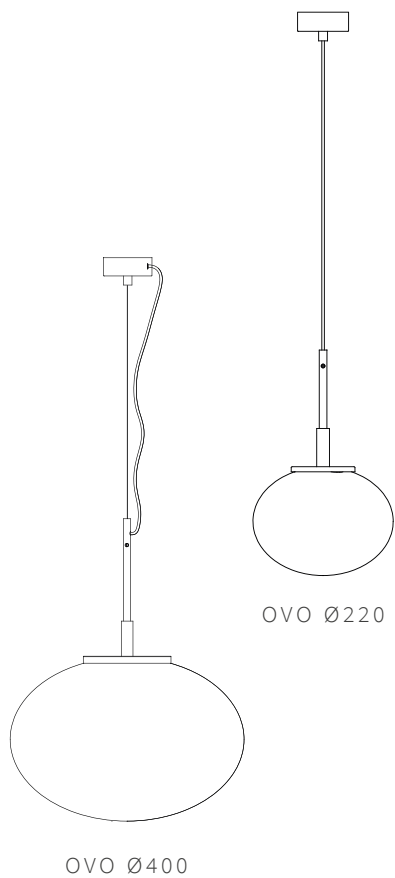

“DESIGN REVEALS WHAT
ART CONCEALS.” MARLENE PROTEAU

BACK

OVAL WISZĄCA/ LA15/A1

OPRAWA WISZĄCA: OVAL

ŹRÓDŁO ŚWIATŁA: E27

MATERIAŁ: SZKŁO „HANDMADE”, STAL



550

N. 35



„GOOD DESIGN HAS NO DEFINITION,
NEEDS NO EXPLANATION. IT HAS ONLY SENSATION.” PAUL SANDIP



CORONA WISZĄCA/ DM102

OPRAWA WISZĄCA: CORONA

ŹRÓDŁO ŚWIATŁA: E27

MATERIAŁ: SZKŁO-Ø200, „HANDMADE”, STAL

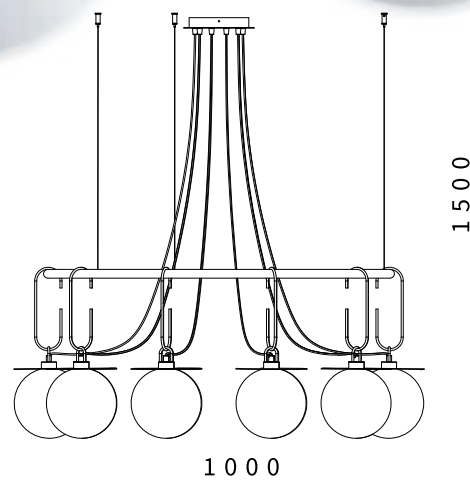

BACK

DUO WISZĄCA / DM104

OPRAWA WISZĄCA: DUO

ŹRÓDŁO ŚWIATŁA: 2XG9; 2X PROJEKTOR LED* SLM L09

MATERIAŁ: SZKŁO-Ø160 I Ø200, „HANDMADE”, STAL, ALUMINIUM

*LED PHILIPS





PROJEKT I ARANŻACJA
STUDIO "BEFORECONCEPT" WNETRZE PRYWATNE



BACK

ALFREDO WISZĄCA / 1408

OPRAWA WISZĄCA: ALFREDO

ŹRÓDŁO ŚWIATŁA: LED*

MATERIAŁ: STAL



*LED PHILIPS

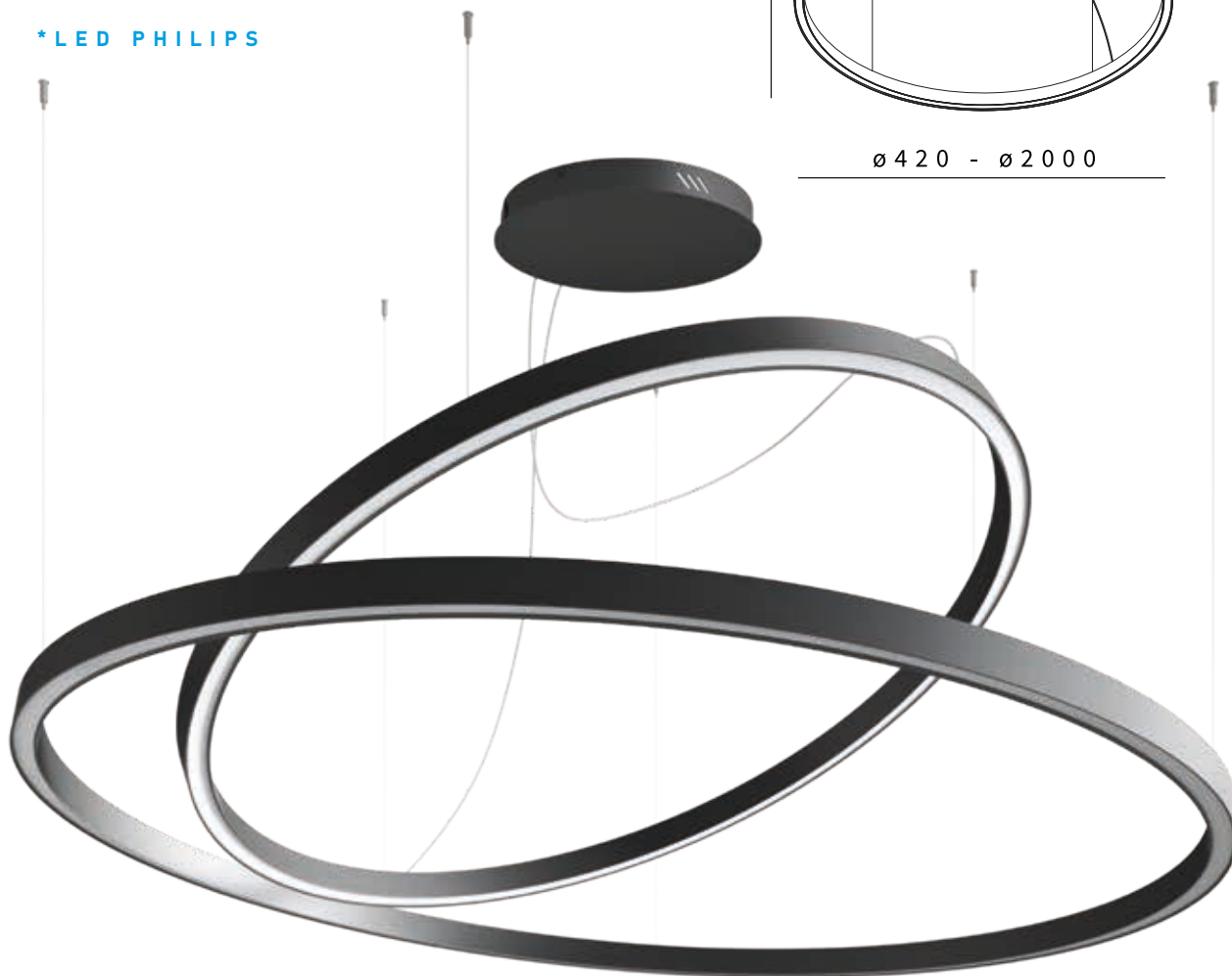
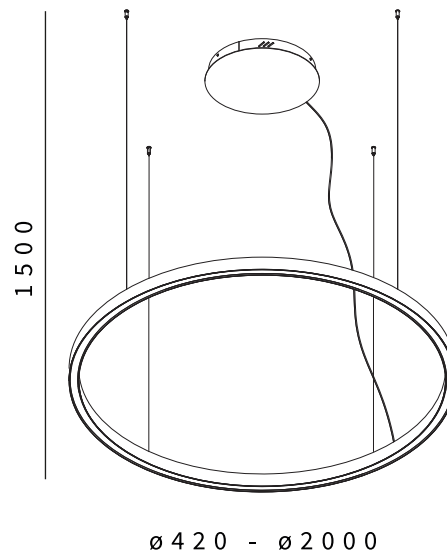

← BACK

ALFREDO PLAFON / 1408

OPRAWA PLAFON: ALFREDO

ŹRÓDŁO ŚWIATŁA: LED*

MATERIAŁ: STAL



* LED PHILIPS



ø 400 - ø 2000



CHARLES EAMES „THE DETAILS ARE NOT THE DETAILS.
THEY MAKE THE DESIGN.”



“DESIGNING IS NOT A PROFESSION BUT AN ATTITUDE...

THINKING IN RELATIONSHIPS.” LASZLO MOHOLY-NAGY

140



Ø 2500 - Ø 6000

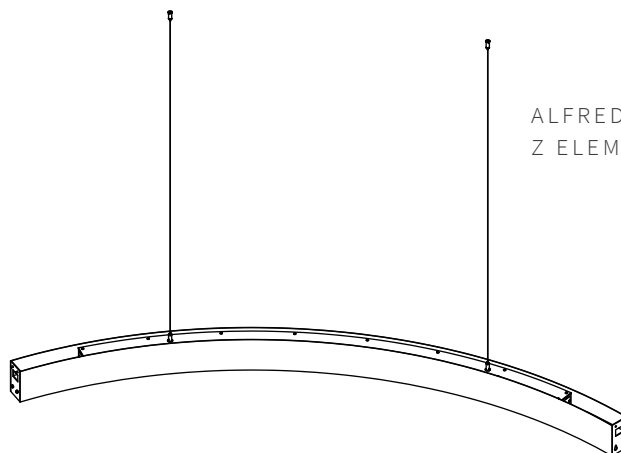

ALFREDO GRANDE ZBUDOWANE JEST Z ELEMENTÓW MODUŁOWYCH.

ALFREDO GRANDE WISZĄCA

OPRAWA WISZĄCA: ALFREDO GRANDE

ŹRÓDŁO ŚWIATŁA: LED*

MATERIAŁ: ALUMINIUM



*LED PHILIPS

BACK

RAD WISZĄCA / 1394

OPRAWA WISZĄCA: RAD

ŹRÓDŁO ŚWIATŁA: LED*

MATERIAŁ: STAL

*LED PHILIPS

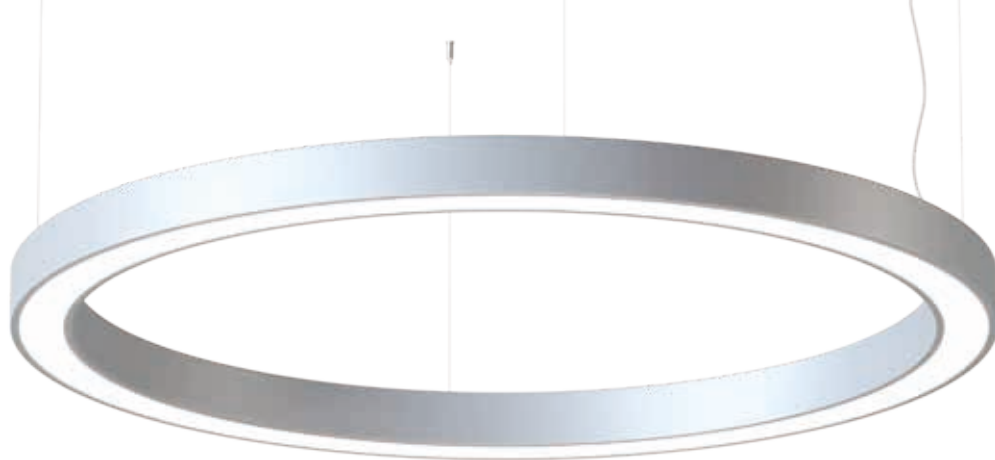

ø 650 - ø 2000

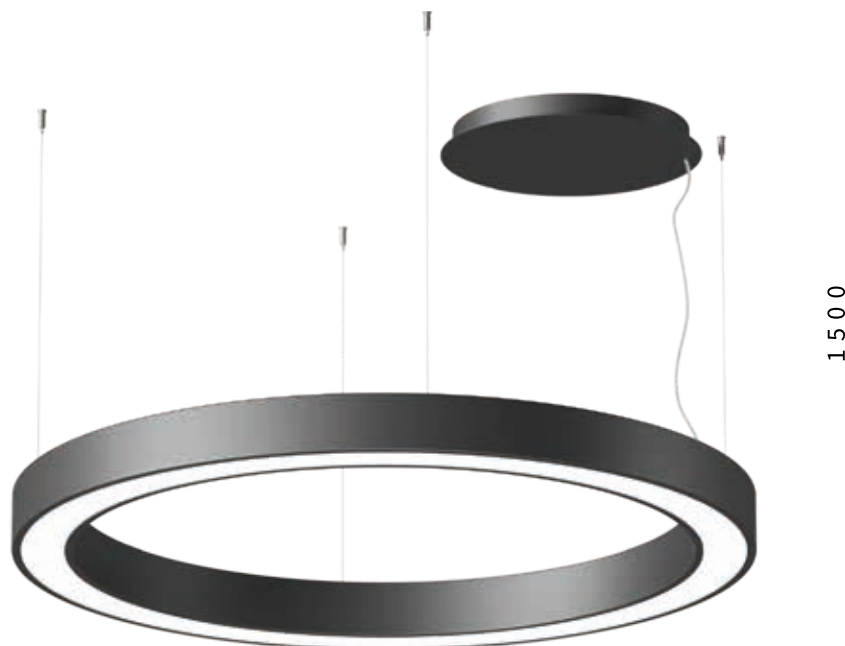



CHARLES EAMES „A DESIGNER IS A PLANNER WITH AN AESTHETIC SENSE.”



BACK

PEDRO WISZĄCA / DM103RA

OPRAWA WISZĄCA: PEDRO

ŹRÓDŁO ŚWIATŁA: LED*, 5X PROJEKTOR LED*

MATERIAŁ: STAL, ALUMINIUM

Bluetooth 

*LED PHILIPS



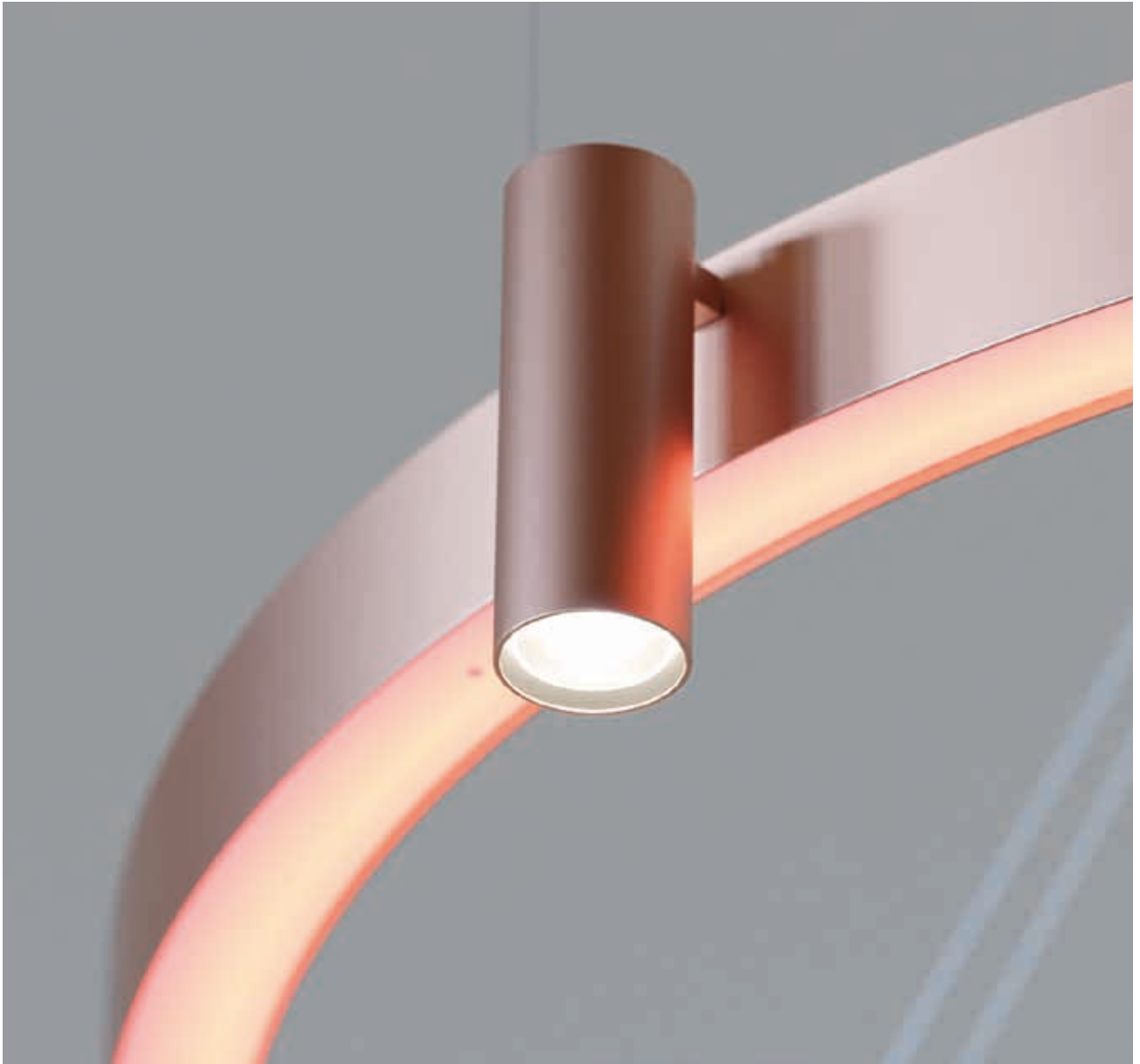

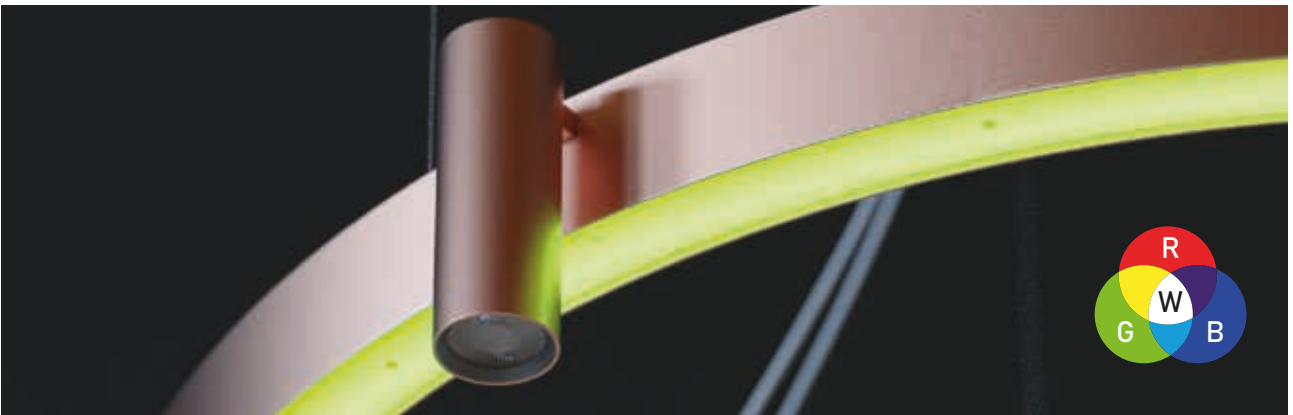
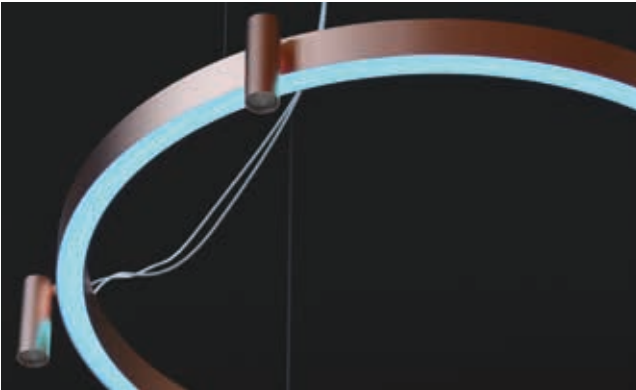

BACK

ABA PREMIUM PLAFON / 1267

OPRAWA PLAFON: ABA PREMIUM

ŹRÓDŁO ŚWIATŁA: LED*

MATERIAŁ: STAL



*LED PHILIPS

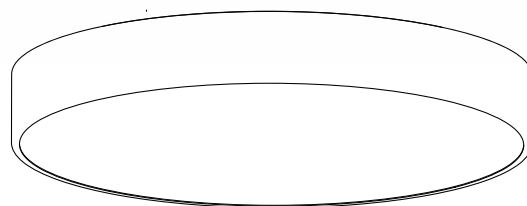

Ø 600 - 1600

170

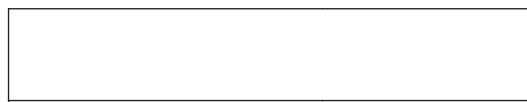



LUDWIG MIES
VAN DER ROHE

„NO DESIGN IS POSSIBLE UNTIL THE MATERIALS WITH
WHICH YOU DESIGN ARE COMPLETELY UNDERSTOOD.”



BACK

ABA PRO WISZĄCA / 1267

OPRAWA WISZĄCA: ABA PRO

ŹRÓDŁO ŚWIATŁA: LED

MATERIAŁ: STAL



1500

120

Ø 300 - Ø 1000

BACK

PIXO / SIL / SILO WISZĄCA / T068

OPRAWA WISZĄCA: PIXO

ELEMENTY DODATKOWE: SIL, SILO

ŹRÓDŁO ŚWIATŁA: GU10

MATERIAŁ: ALUMINIUM

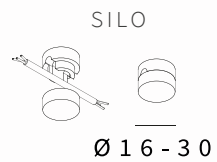
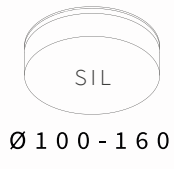
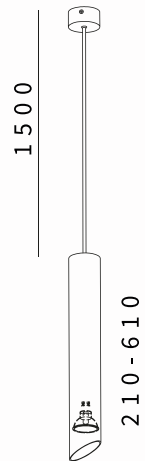



“DESIGN IS LIKE GRAVITY - THE FORCE THAT
HOLDS IT ALL TOGETHER.” EDGAR A. WHITNEY



ATEGO WISZĄCA / 12391

OPRAWA WISZĄCA: ATEGO

ŹRÓDŁO ŚWIATŁA: E27, LED

MATERIAŁ: SKLEJKA FORNIROWANA LUB MALOWANA



BACK

LAKARI KINKIET/ LA110

OPRAWA - KINKIET: LAKARI

ŹRÓDŁO ŚWIATŁA: LED

MATERIAŁ: ALUMINIUM

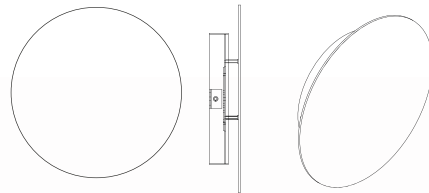

Ø 150 - Ø 600





CHARLES EAMES

„RECOGNIZING THE NEED IS THE PRIMARY
CONDITION FOR DESIGN.”

NER WISZĄCA/T169

OPRAWA WISZĄCA: NER
ŹRÓDŁO ŚWIATŁA: G9 LED
MATERIAŁ: STAL



1500



300 - 600



NER PANEL-CLEONI

STOISKO TARGOWE WARSAW HOME



COPPER

NER
NER PANEL

MATERIAL STAL

ŹRÓDŁO ŚWIATŁA 14xG9 LED

COLOR 961

WERSJA ZBH14



GOLD

NER
NER PANEL

MATERIAL STAL

ŹRÓDŁO ŚWIATŁA 7xG9 LED

COLOR 962

WERSJA ZBH7



NER PANEL WISZĄCA / T169

OPRAWA WISZĄCA: NER PANEL

ŹRÓDŁO ŚWIATŁA: G9 LED

MATERIAŁ: STAL

SILVER
& BLACK

NER
NER PANEL

MATERIAL STAL

ŹRÓDŁO ŚWIATŁA 20xG9 LED

COLOR 963; 196

WERSJA ZPD20



NERON WISZĄCA / T174

OPRAWA WISZĄCA: NERON

ŹRÓDŁO ŚWIATŁA: G9

MATERIAŁ: STAL

WERSJA POJEDYŃCZA

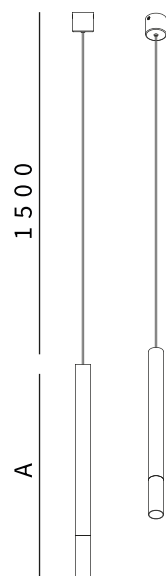

ELEMENT "A"

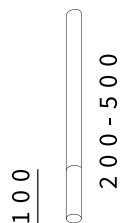

WERSJA PANEL

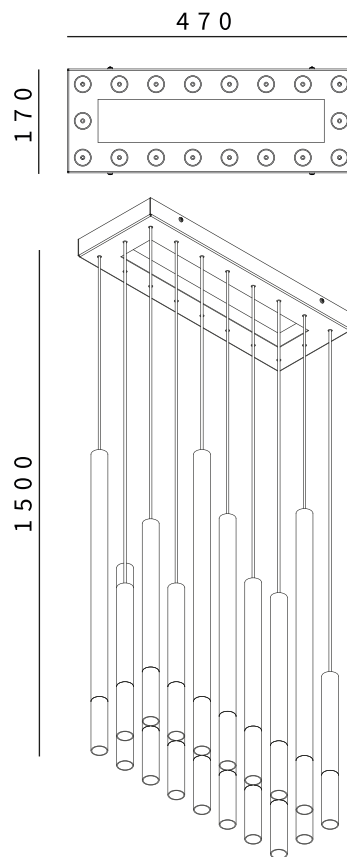



HARRY SEIDLER „GOOD DESIGN DOESN'T DATE.”



„DESIGN IS NOT FOR PHILOSOPHY
IT'S FOR LIFE.” ISSEY MIYAKE

SERISA KINKIET/ 1404

OPRAWA KINKIET: SERISA

ŹRÓDŁO ŚWIATŁA: LED

MATERIAŁ: STAL

WERSJA A3

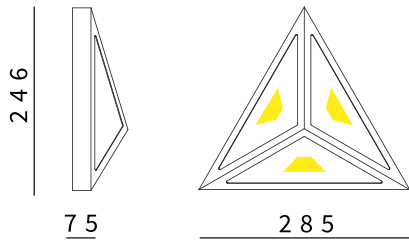

WERSJA A2

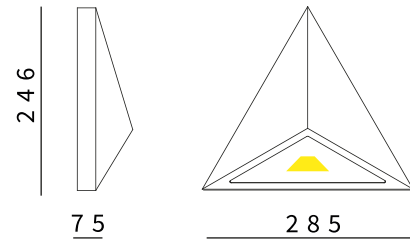

WERSJA A1

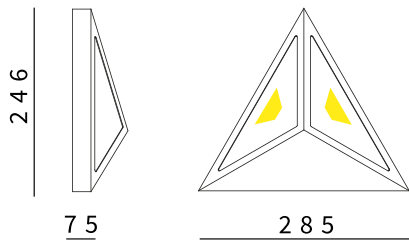

WERSJA AP

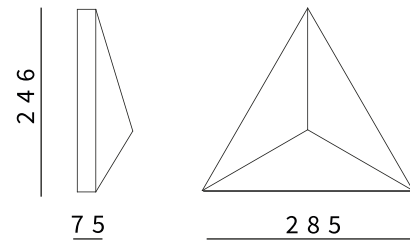

BACK

IMA WISZĄCA / T170

OPRAWA WISZĄCA: IMA

ŹRÓDŁO ŚWIATŁA: LED

MATERIAŁ: ALUMINIUM





DONNA KARAN

„DESIGN IS A CONSTANT CHALLENGE TO BALANCE COMFORT
WITH LUXE, THE PRACTICAL WITH THE DESIRABLE.”



ROB 80 PROJEKTOR TRACK/ TSL43

OPRAWA PROJEKTOR TRACK: ROB 80

ŹRÓDŁO ŚWIATŁA: LED

MATERIAŁ: ALUMINIUM

WERSJA TL

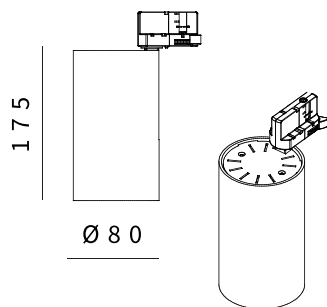

WERSJA HF

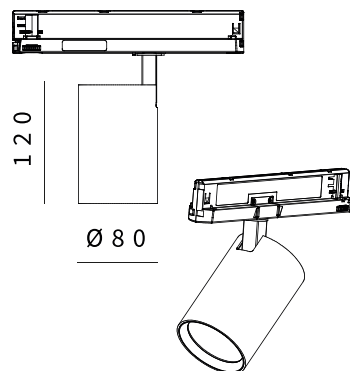

ROBEN PROJEKTOR TRACK / T218

OPRAWA PROJEKTOR TRACK: ROBEN

ŹRÓDŁO ŚWIATŁA: LED

MATERIAŁ: ALUMINIUM

WERSJA TL



WERSJA HF

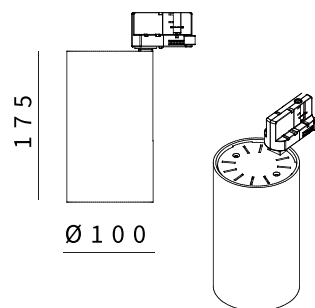
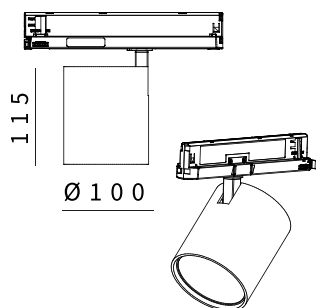



ARIS CONCEPT | SALON MEBLOWY



ASTOR LED SLM WISZĄCA TRACK/ T117

OPRAWA WISZĄCA - TRACK: ASTOR LED SLM

ŹRÓDŁO ŚWIATŁA: LED* SLM

MATERIAŁ: ALUMINIUM



*LED PHILIPS

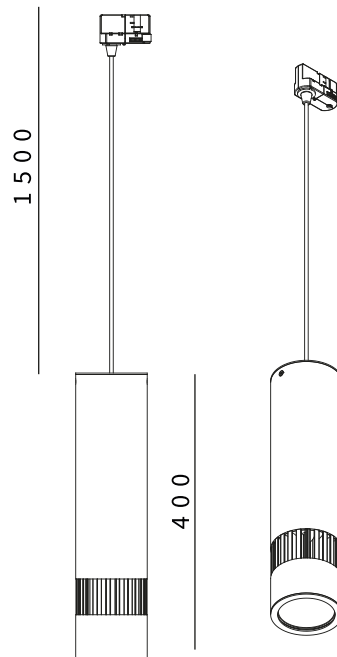

BACK

ASTOR LED SLM TRACK / T117

OPRAWA TRACK: ASTOR LED SLM TRACK

ŹRÓDŁO ŚWIATŁA: LED* SLM

MATERIAŁ: ALUMINIUM



*LED PHILIPS

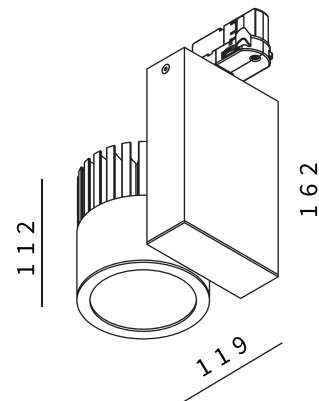



THOMAS J. WATSON

„DESIGN MUST REFLECT THE PRACTICAL AND AESTHETIC
IN BUSINESS BUT ABOVE ALL... GOOD DESIGN MUST
PRIMARILY SERVE PEOPLE.”



N^o.₈₀

GENEVIEVE GORDER

„SO, TO REALLY EXECUTE DESIGN IN ITS HIGHEST FORM
AND MAKING PEOPLE FEEL JOY, THAT’S A GREAT REWARD.”

BACK

ASTOR LED SLM PROJEKTOR STROPOWY/ T117

OPRAWA PROJEKTOR STROPOWY: ASTOR LED SLM

ŹRÓDŁO ŚWIATŁA: LED* SLM

MATERIAŁ: ALUMINIUM



*LED PHILIPS

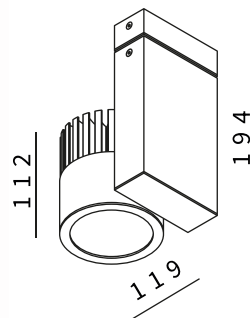

BACK

TUBE LED SLM PROJEKTOR TRACK/ T215

OPRAWA PROJEKTOR TRACK: TUBE LED SLM

ŹRÓDŁO ŚWIATŁA: LED* SLM

MATERIAŁ: ALUMINIUM



*LED PHILIPS

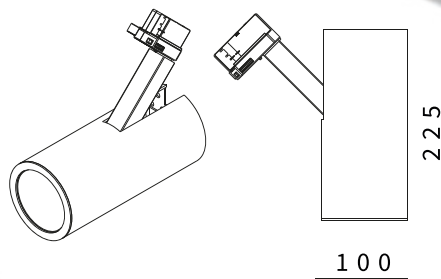



KANYE WEST „ART IS TO BE FREE. DESIGN IS TO FIX.”



DESTINATION		DEPARTURE
COFFEE		
DAILY BREW		
CAMP CUP		
COLD BREW		
ESPRESSO		
+WATER		3.00
+MILK MINI		3.00
+MILK SML		3.50
+MILK MED		4.00
+MILK LRG		4.50
+CHOCOLATE		+1.00
+ALMOND		+1.00
CHAI		5.00
TEA		4.00

SEE SIGNATURE MENU
WHEELHOUSE

ANN LED SLM PROJEKTOR TRACK/ T214

OPRAWA PROJEKTOR TRACK: ANN LED SLM

ŹRÓDŁO ŚWIATŁA: LED* SLM

MATERIAŁ: ALUMINIUM



*LED PHILIPS

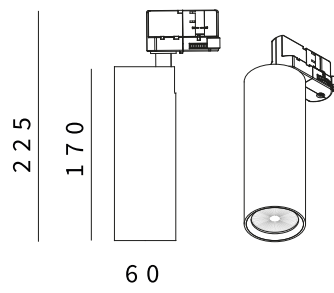

BACK

DENON WPUST STROPOWY/ T191RT

OPRAWA WPUST STROPOWY: DENON

ŹRÓDŁO ŚWIATŁA: LED

MATERIAŁ: STAL

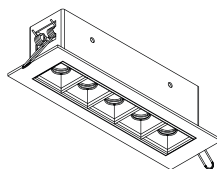
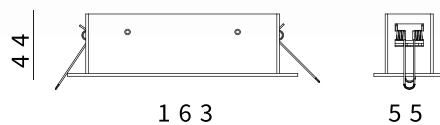



DIETER RAMS

„DESIGN SHOULD NOT DOMINATE THINGS, SHOULD NOT DOMINATE PEOPLE. IT SHOULD HELP PEOPLE. THAT'S ITS ROLE”

N. 87



ATIKA, CLIO, DOMINO, ENZO, INTE, GEOPOL

WPUST STROPOWY

OPRAWA WPUST STROPOWY: ATIKA, CLIO, DOMINO, ENZO, INTE, GEOPOL

ŹRÓDŁO ŚWIATŁA: LED

MATERIAŁ: ALUMINIUM

ATIKA-LED, LED SLM



CLIO-LED SLM



DOMINO-LED ERC



ENZO-LED, LED SLM



INTE-LED SLM



GEOPOL-LED, LED SLM



CLEONI

**UL. USŁUGOWA 19
ROŻNOWO, 64-600 OBORNIKI**

WWW.CLEONI.PL